

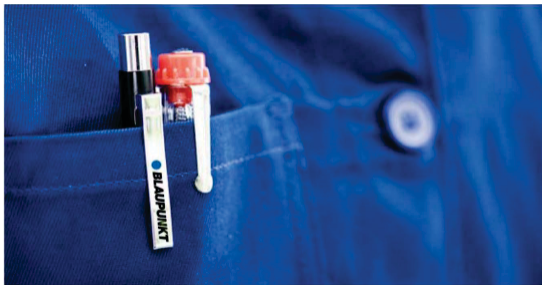

The Manufacturer does not guarantee for possible inexactitudes due to printer's or transcription errors, contained in this booklet. He reserves the right to bring in any moment modifications he should judge necessary or useful.

### Service



Blaupunkt integrated kitchen appliances/customer services:

Tel: 180 2092096

[customer\\_service@hepoindia.com](mailto:customer_service@hepoindia.com)

You have chosen a piece of premium kitchen equipment with Blaupunkt appliances. Our professional service is available to assist you after the purchase. Our qualified employees are pleased to remain at your disposal. Our customer service experts for Blaupunkt integrated kitchen appliances will professionally answer all questions about the appliances. Here you will receive all the information on handling, functions and performance.



**Convincing quality with Blaupunkt guarantee.**  
Blaupunkt kitchen appliances are exclusively produced from the best materials and according to the highest working standards. Blaupunkt provides a two-year manufacturer's guarantee on every appliance and every repair carried out by the Integrated kitchen appliances customer service.



Your direct route to Blaupunkt.  
[www.blaupunkt-einbaugeräte.com](http://www.blaupunkt-einbaugeräte.com)



**More original: Accessories and spare parts.**  
Original spare parts, extensive accessories and tested detergents and care products can be bought from our competent employees.



**In your vicinity - and fast. Our specialists from Blaupunkt.** With a nationwide service network and approximately 700 highly qualified technicians, we can guarantee that our specialists are always quickly on location in case of repair. The standard time is within 48 hours.

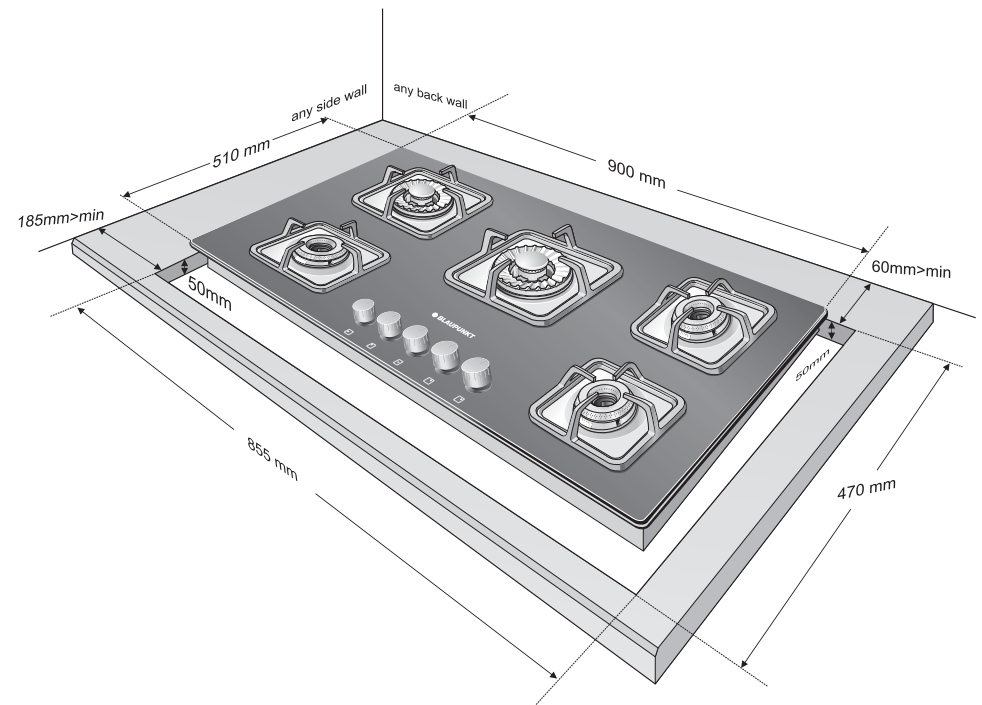

# Built In Gas Hobs

## Instructions for Installation and use

# INDEX

## GENERAL WARNINGS

### Instructions for Use:

- Description of the main parts of the appliance 4
- Gas burners (operation, Lighting) 5
- Maintenance & cleaning 6
- Advice on the use of gas burners 7
- Container table (use flat-bottomed saucepans) 7

### Instructions for Installation:

- Positioning & gas Connection 8-9
- Electrical connection 10
- Burner and nozzle characteristic table 11
- Instructions for building in the units 12
- Size of Hobs and Cutting Dimension 13
- Illustrations 14

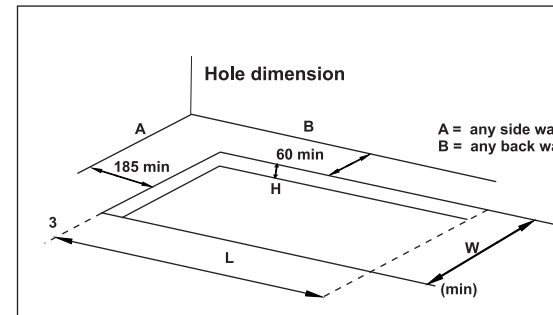

Fig. 1

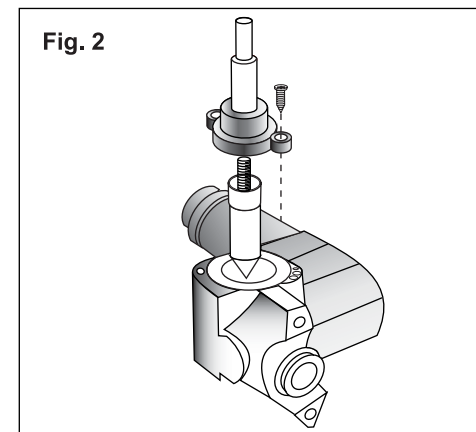
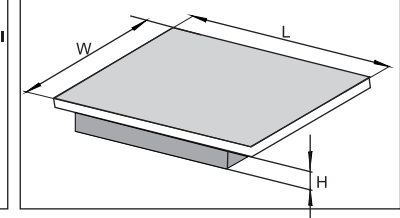

Fig. 2

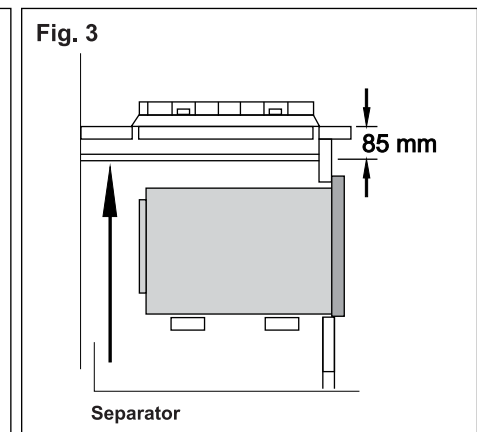

Fig. 3

Separator

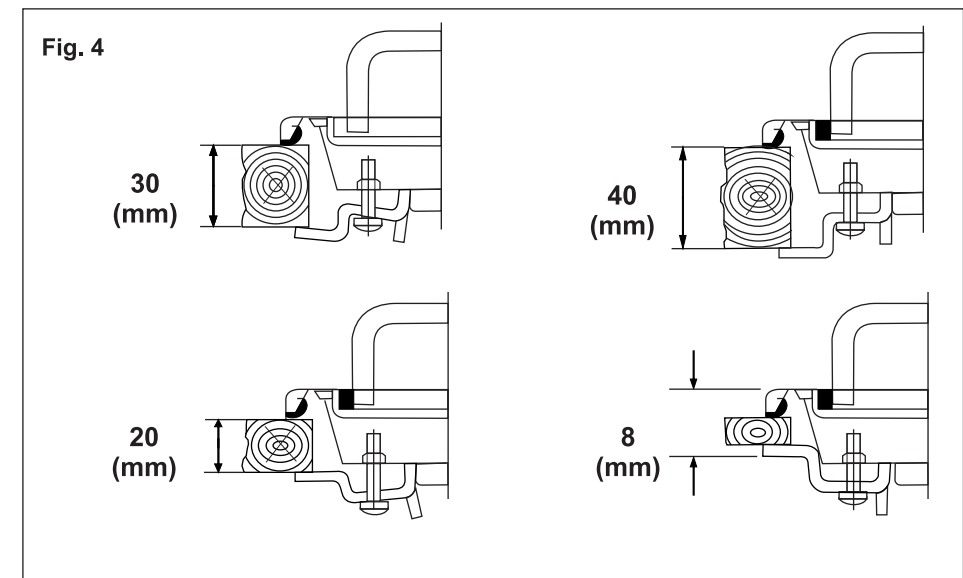

Fig. 4

## Sizes of Hobs and Cutting Dimension:

Hob Model Type	Dimensions L x W ( mm )	Cutting Dimensions L x W ( mm )
A	720 x 530	575 x 480 x 50
B	610 x 500	565 x 475 x 50
C	650 x 510	595 x 470 x 50
D	900 x 510	855 x 470 x 50

**A:** BKP 5GH27BB92/ BKP 5GH27BB93

**B:** BKP 5GH11BB5

**C:** BKP 5GH27BB94

**D:** BKP 5GH29BB95

---

Before leaving the factory this appliance was checked and prepared by expert and specialized personnel in order to give the best functioning results. Any repairs or adjustment which might be necessary is to be carried out with the utmost care and attention.

For this reason we recommend you always contact the dealer where the appliance was sold or our nearest Customer Service Centre, specifying the type of problem and the model of your appliance. Do not forget that the original spare parts are only to be found at our Customer Service Centres

---

## General Warnings

Dear Customer,

**Thank you for choosing our product. This appliance is easy to use; read this handbook carefully before installing and using it, however. You will find the correct indications for the best installation, use and maintenance of the product.**

- ◆ Attention : you will find the guarantee certificate in the appliance packaging. This must be returned correctly filled in, within 8 days.
- ◆ Very important : Keep this instruction booklet with the appliance in case you pass it on to someone else.
- ◆ **This appliance is class 3 and is designed for non-professional use by private individuals at home. It must be used by adults. Do not allow children to play near it. Supervise children when it is being used so that they do not touch hot surfaces and are not near the appliance while it is in use.**
- ◆ The Product installation must be performed by competent and qualified installers who are aware of the installation regulations in force.
- ◆ Before maintenance or cleaning disconnect the appliance from the mains and wait for it to cool down.
- ◆ When the burners are lit check that the flame is always regular. Before removing the saucepans turn the burners off.
- ◆ The use of a gas appliance requires a regular exchange of air. Make sure that the installation complies with the "Positioning" section.
- ◆ If a gas appliance is used for a long time it may require extra ventilation (opening a window or increase of the forced exhaust).
- ◆ Be careful not to place saucepans with unstable or deformed bottoms on the burner to avoid accidents by overturning or spilling over of liquid.
- ◆ If a burner is turned off accidentally turn off the control knob and try to light it again after waiting at least a minute.
- ◆ For any repairs always contact an authorised technical Customer Service Centre and ask for original spare parts. Repairs by untrained people can lead to damage.

## Instructions for installation

### Instructions for building in the units

The appliance is of Y type, or it can be installed with just one side part (to right or left of the hob) higher than the cooking hob and placed at a minimum distance as shown in fig.1

It can be built into all units whose walls withstand a temperature 65° C higher than room temperature (EN 60335 - 2 - 6).

Avoid installing the appliance near inflammable materials (e.g. curtains, cloths, etc.)

### Dimensions, insertion and assembly

The appliances are designed to be inserted in units with a minimum depth of 550 mm.

The dimensions of the openings for building in are given in fig. 1 which also gives the minimum distances to be respected between the hole for building in and the side and back walls.

### Steel or enameled plate hobs

- ◆ Position the special sealed gasket (provided) on the edge of the hob making sure that the ends meet without one lying on top of the other.
- ◆ Put the hob in the unit opening making sure that it is centred.
- ◆ Fasten the hob to the unit with the fastening brackets (see fig. 4). The traction of the screws will be enough to cut the sealing gasket so that the excess can easily be removed.

### Warnings

If there is a hanging unit over the cooking hob it must be at least 600 mm away from it.

To avoid excessive overheating, if the hob is coupled with an oven, there must be a separation sector (fig. 3).

This sector is recommended if the hob has triple ring burners.

## Instructions for Installation

## Instructions for Use

### Burner And Nozzle Characteristic Table

#### CAT. II 2H3 +

	Burner (heights enamelled cover) (mm)	By Pass 1/100 mm	Thermal Power (*) (kw)		Liquid Gas	
			Rated	Reduced	Output(g/h) G 30	Injector 1/100 mm
ITALIAN BURNER	Large (Ø = 100)	0.44	3	0.9	218-214	85
	Medium (Ø = 75)	0.34	1.75	0.6	227-125	65/50
	Small (Ø = 55)	0.29	1	0.45	73-71	50
	Triple ring normal (Ø = 132)	0.64	3.5	1.6	254-250	95/85
	Tripal ring Big) (Ø = 132)	0.65	3.8	1.8	276-272	100
	Tripal ring Mini (Ø = 102)	0.55	2.5	0.9	222-218	0.82
BRASS BURNER	Semi Rapid Lotus S4	0.44	1.70	0.9	123.6	0.75
	Rapid Lotus S4	0.50	2.50	0.9	181.1	0.90
	Torch (Duel Burner)	0.65	3.50	0.3	254.6	0.83/0.43
HOB COOKTOP HYBRID	Mini Triple Ring Burner	0.75	3.70	0.9	123.6	0.75
	Double Ring Burner	0.65	2.5	0.9	85-80	0.60
Rate supply pressure (mbar) (1 mbar = 10, 197 mm H <sub>2</sub> O)					G230 = 28 - 30	
Electrical power supply = 230V - 50/60 Hz						

(\*) = with dry gas and with greater calorific power (H<sub>2</sub>) at 15°C and 1013.26 mbar

### Description of the main parts of the appliance

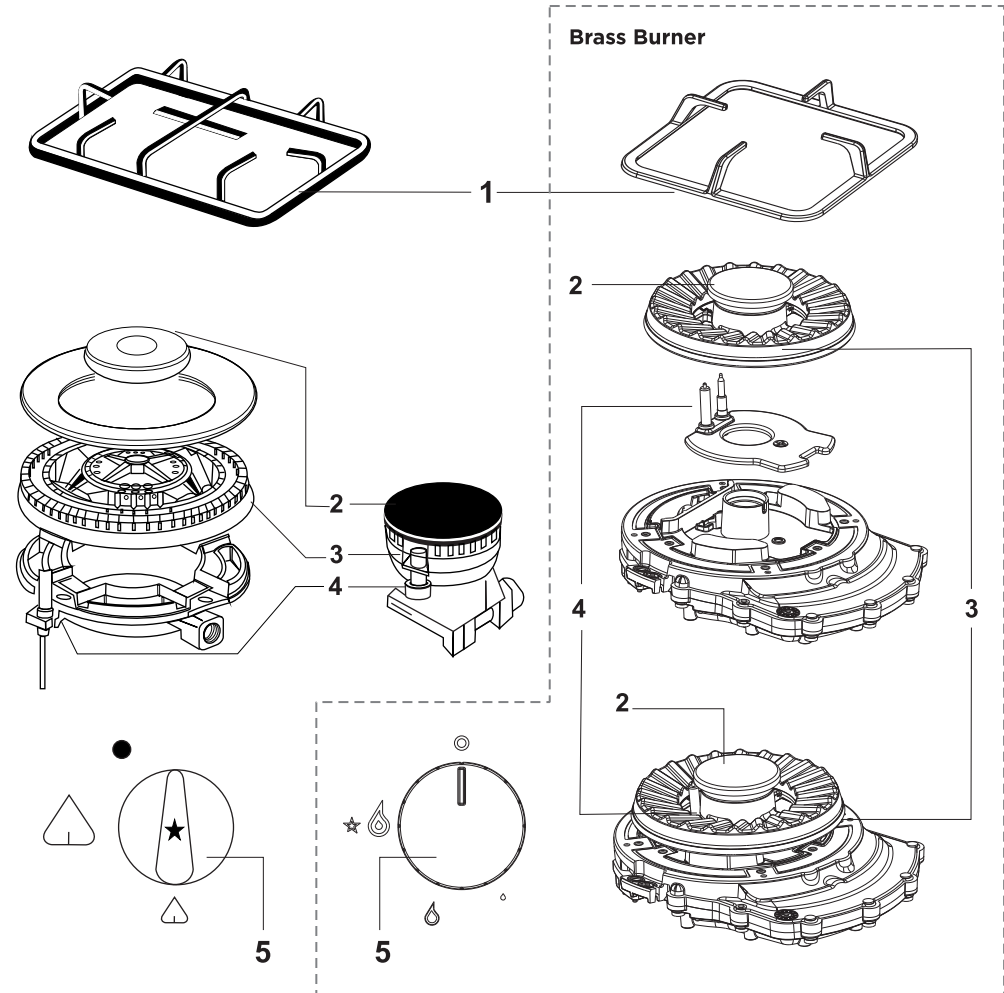

- 1= grid
- 2= enamelled cover
- 3= spreader
- 4= ON spark plug (for versions with lighting)
- 5= gas burner control knob (\* ON switch on the knob for the versions so equipped)

## Instructions for use

The hob control area houses the devices and knobs for operation of the gas burners.

### Operation of gas burners

The burner regulation knobs can be turned anticlockwise from the closing position to the widest open position and vice versa in the opposite direction (put the needle to the position required):

- = no gas supply
- △ = maximum gas supply
- △ = minimum gas supply

### Lighting The Burners

For models equipped with electrical ignition device, the ignition of burners takes place by pressing and rotating the knob until the position of maximum output is reached. In the versions with separate ignition key, only press this key and at the same time press and rotate the knob proportional to the desired burner, until it reaches the position of maximum output. If a burner is turned off accidentally or does not light, turn the control knob OFF and repeat the lighting after at least 1 minute.

## Instructions for installation

### Electrical connection

Appliances with three-pole cable are set up for operation with alternating current at the voltage and frequency indicated both on the rating plate (on the lower part of the appliance) and the Table (see page 10).

The earth conductor is yellow /green.

The connection to the electricity supply must be made by a qualified person and following the regulations in force.

When the appliance is to be installed above a built-in oven, the two appliances must be connected separately, to make it easier to take the appliances out and for electrical safety.

### Connection of the supply cable to the mains

Connect a plug sized for the load indicated on the rating plate to the cable and connect it to a suitable socket. Avoid the use of reductions, two-way or adapters to avoid overheating or burning.

For direct connection to the mains there must be an omnipolar switch with minimum opening between the contacts of 3 mm sized for the load and corresponding to the standards in force between the appliance and the mains. The yellow / green earth wire must not be interrupted by this switch.

The brown/Red phase wire must be connected to the supply mains phase.

The supply cable must be so positioned that no point can reach a temperature 50°C higher than ambient temperature.

Before making the electrical connection check that the domestic system and the limiter valve can take the appliance load (see rating plate or Table in the instruction booklet.)

Also check that the supply system has an effective earth connection and corresponds to the standards in force and that the plug (or omnipolar switch) can be reached easily when the appliance is installed

## Instructions for installation

- For safety operation make sure that the supply pressure respects the values given in the "Table of burner and injector characteristics".
- If the appliance is supplied with liquid cylinder gas, make sure that the cylinder pressure regulator conforms to the local regulations in force.

### Gas Connection

- The appliance must be connected to the gas system by a rigid metal pipe (copper or steel) or continuous wall stainless steel flexible hose in such a way that the appliance is not stressed in any way.
- The appliance gas inlet tube has an end nut to which is connected the elbow union (supplied; 1/2 thread male gas). It can be turned depending on installation needs.
- The rigid or flexible metal supply pipe is connected to the part opposite the elbow union. Remember to put the gaskets supplied at the two ends of the elbow union.
- When these parts are disassembled and reassembled, always replace the gaskets with new ones.
- Once the appliance is installed, check that the gas pipe is not pinched or damaged by mobile parts.

**Important:** When installation is complete, check that all the gaskets are leaktight using a soap-based solution, never a flame.

**Warning:** The use of a gas appliance produces heat and humidity in the room where it is installed. Make sure that the room is well ventilated, keeping the natural ventilation outlets open or installing a ventilation hood with drain duct.

## Instructions for use

### Maintenance and cleaning

Before any operation disconnect the appliance electrically. Wash the enameled parts with lukewarm water and detergent. Do not use abrasive products.

Wash the burner spreader frequently with boiling water and detergent being sure to remove any deposits which could block the flame outlet. Rinse the stainless steel parts well with water and dry them with a soft cloth.

To clean the hob use slightly damp sponges and wiping cloths: if too much water is used it could penetrate the internal parts and damage electrical parts.

The grids of the hob can be washed in the dishwasher.

For persistent stains use normal non-abrasive detergents, specific products commonly available on the market or a little hot vinegar. Clean the glass hob with hot water, avoiding the use of rough cloths.

Do not use stainless steel pads or acids for cleaning.

To prevent lighting difficulties, carefully clean the lighting spark plugs regularly (cermic and electrode)

Periodically, or if the knobs become difficult to turn, contact a qualified engineer to lubricate the taps.

Contact a qualified engineer to deal with any other problems which may arise during use.

## Instructions for use

When the burner is lit adjust the flame as required.

To turn the gas supply OFF turn the knob clockwise to the «●» position.

### Advice on the use of gas burners

For lower gas consumption and a better yield, use saucepans with diameter suitable for the burners, avoiding the flame coming up round the side of the saucepan (see the Container Table). Use only flat- Bottomed pans. As soon as a liquid starts to boil, turn the flame down to a level sufficient to maintain boiling. During cooking, when using fats and oils, be very careful because if they overheat they could catch fire.

### Container table (use flat-bottomed saucepans)

<b>Burners</b> (heights enameled cover) mm	(Ø min. Saucepan (mm))	(Ø max. Saucepan (mm))
Small (Ø=55)	90	160
Medium (Ø=75)	130	180
Large (Ø=100)	150	260
Triple ring Normal (Ø=128)	210	270
Triple ring Big (Ø=132)	220	280
Triple ring Mini (Ø=102)	160	270

## Instructions for installation

Below we give the instructions for qualified installers so that the installation, setting and maintenance operations are performed correctly and according to the regulations in force.

### Positioning

- The appliance can only be installed and operate in permanently ventilated rooms according to the local regulations in force.
- The natural flow of air must be direct through permanent holes made in the walls of the room to be ventilated leading to the outside, or through single or collective branched ventilation ducts.
- The ventilation openings must have a effective cross-section of at least 100 cm<sup>2</sup> and must be protected against accidental blocking (protection with metal grills or grids). For appliances without safety valve on the hob, the opening section is doubled with a minimum of 200 cm<sup>2</sup>.
- There may also be an indirect flow of air from rooms next to that where the appliance is installed, as long as these rooms have direct ventilation, there is no fire risk in these rooms and they are not bedrooms.
- The flow of air between adjacent room and the room where it is installed must be free through permanent openings (which may be obtained by making the gap between door and floor larger).
- In the room where it is installed there must be a system for leading the combustion fumes to the outside. This may be with a hood or an electric fan which switches on when the appliance is switched on.

### Gas Connection

- The appliance must be connected to the gas supply or the cylinder according to the specifications of the standards in force and after checking that it is adjusted for the type of gas available.
- The appliance is set up to operate with the gas specified on the calibration label placed both on the packaging and on the back of the appliance.